

Modular Cooking Range Line EVO700 4 Hot Plate Electric Induction Cooking Top HP

ITEM # _____

MODEL # _____

NAME # _____

SIS # _____

AIA # _____



372176 (Z7INEH400P)

4-zone (5 kW each) electric
induction cooking top - hp

Short Form Specification

Item No. _____

6 mm thick glass ceramic cooking surface with 4 independently controlled 5 kW induction zones. Induction top surface with seamless transition between individual heating zones. Exterior panels in stainless steel with Scotch Brite finish. One piece pressed work top in 1.5 mm thick stainless steel. Right-angled side edges to allow flush-fitting junction between units.

Main Features

- 6mm glass ceramic cooking surface with 4 independently controlled induction zones with a power of 5 kW per zone.
- Almost the entire surface of the ceramic plate can be used without "dead" spots.
- Indicating lamp for each zone located on control console.
- Induction plates endowed with overheating safety device.
- Power to the individual zones can be set with progressive output i.e. fine regulation at the lower and larger progress at the upper levels.
- Low heat dissipation to the kitchen.
- The smooth, glass ceramic plate is not directly heated, so there is no burning on cooking surface.
- IPx4 water protection.
- Pots diameter to be used : min 12cm, max 28 cm in order to obtain maximum heating efficiency.

Construction

- All exterior panels in Stainless Steel with Scotch Brite finishing.
- One piece pressed 1.5 mm work top in Stainless steel.
- Model has right-angled side edges to allow flush fitting joints between units, eliminating gaps and possible dirt traps.

APPROVAL: _____

Optional Accessories

- Support for bridge type installation, 800 mm PNC 206137
- Support for bridge type installation, 1000 mm PNC 206138
- Support for bridge type installation, 1200 mm PNC 206139
- Support for bridge type installation, 1400 mm PNC 206140
- Support for bridge type installation, 1600 mm PNC 206141
- Water column with swivel arm (water column extension not included) PNC 206289
- Water column extension PNC 206291

- Chimney upstand, 800 mm PNC 206304

- 2 side covering panels, height 250 mm, depth 700 mm PNC 206320
- Base support for feet or wheels - 800mm (EVO700/900) PNC 206367
- Chimney grid net, 400mm PNC 206400

- Stainless steel universal frying pan with stainless steel handle (diam. 200 mm) suitable for induction and all other heating sources PNC 653596
- Universal frying pan with stainless steel handle (diam. 240 mm) suitable for induction and all other heating sources PNC 653597
- Universal frying pan with stainless steel handle (diam. 280 mm) suitable for induction and all other heating sources PNC 653598

Front

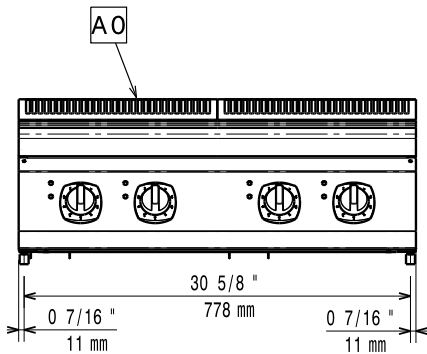

Side

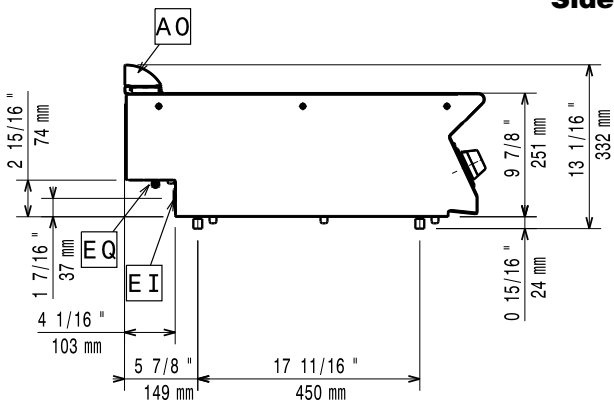

EI = Electrical inlet (power)
EQ = Equipotential screw

Top

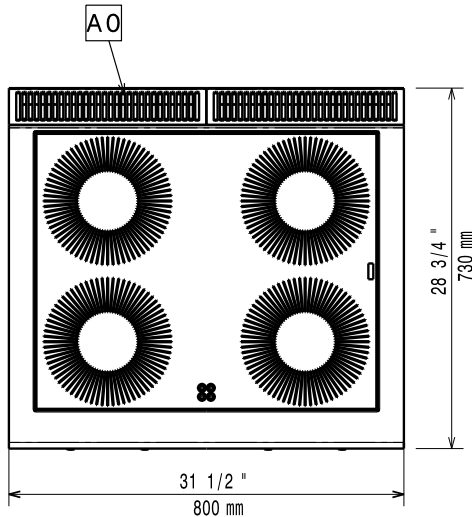

Electric

Supply voltage:

372176 (Z7INEH400P) 380-415 V/3 ph/50/60 Hz

Total Watts:

20 kW

Predisposed for:

380-415V 3~ 50/60Hz 20kW

Key Information:

Induction Top Dimensions (width): 800 mm

Induction Top Dimensions (depth): 700 mm

Net weight: 65 kg

Shipping weight: 68 kg

Shipping height: 520 mm

Shipping width: 820 mm

Shipping depth: 860 mm

Shipping volume: 0.37 m³

If appliance is set up or next to or against temperature sensitive furniture or similar, a safety gap of approximately 150 mm should be maintained or some form of heat insulation fitted.

Induction compatible pots & pans must be used.

Certification group: IH74P